

NOTES:

1. CONCRETE: 4000 PSI
AFTER 28 DAYS
2. REINFORCING: RING
6 X 6/10 X 10
W.W.M., #5 BAR IN COVER.
3. CAPACITY OF 420 GALLONS
PLUS CAPACITY OF
CRUSHED STONE BACKFILL.
4. 24" DIA CAST IRON FRAME
& COVER/GRATE CAN
BE CAST IN OR 24" DIA
OPENING CAST IN AND
FRAME & COVER/GRATE
SHIPPED LOOSE.
5. RINGS MAY BE STACKED ONE
ON TOP OF ANOTHER
FOR MORE CAPACITY.
6. 160 DRAIN OPENINGS
IN CONCRETE.
7. WEIGHT = 1320 LBS.

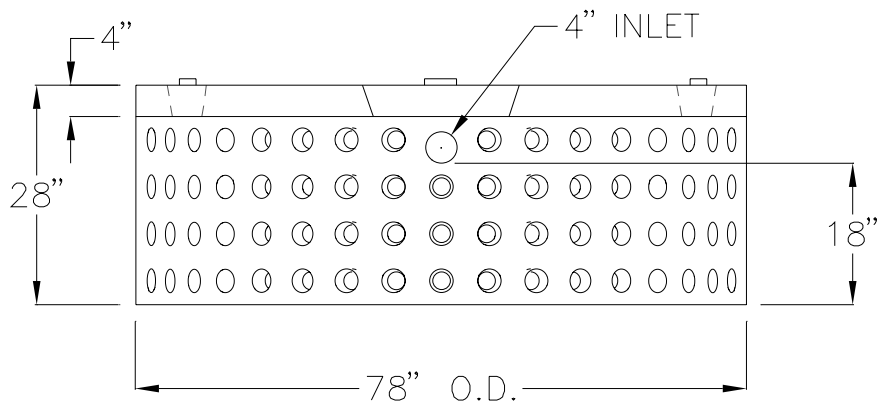
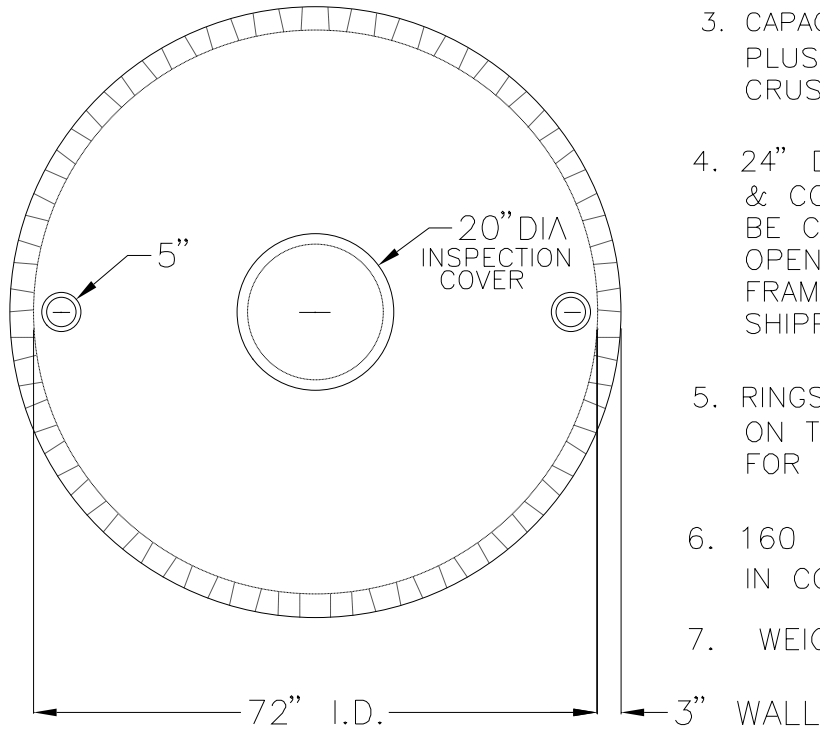

- 78" X4" COVER = 1624 LBS.
- 78" X8" COVER = 3247 LBS.
- 73" X4" COVER = 1426 LBS.
- 64" X4" COVER = 1109 LBS.

RICHARD GENEST, INC.

**CONCRETE
DRAINAGE RING**